



Application Note: AN_SY8722A

High Efficiency, Flicker-free MR16 LED Driver Preliminary Specification

General Description

SY8722A is a high efficiency, flicker-free, MR16 LED driver which is powered by electronic transformer. The device integrates two DC/DC regulators. The first stage boosts the input voltage to a setting value and provides power supply for the second stage. The second stage regulates the LED current to the target value. With proprietary control scheme, the LED driver is compatible with most of commonly used electronic transformers. The high switching frequency allows the use of small size inductor and capacitor. The integrated low $R_{DS(ON)}$ MOSFETs reduce the power loss. Along with compact SO8E package, SY8722A provides ideal solution for MR16 LED lighting.

Ordering Information

SY8722A
 Temperature Code
 Package Code
 Optional Spec Code

Ordering Number	Package type	Note
SY8722AFCC	SO8E	--

Features

- Wide input range: 4-30V
- CH1:100mΩ internal low $R_{DS(ON)}$ MOSFETs
- CH2:200mΩ internal low $R_{DS(ON)}$ MOSFETs
- Fixed switching frequency:
 - CH1: 400KHz
 - CH2: 300KHz
- Flicker Free
- Compatible with most of electronic transformer
- RoHS Compliant and Halogen Free
- Compact package: SO8E

Applications

- MR16

Typical Applications

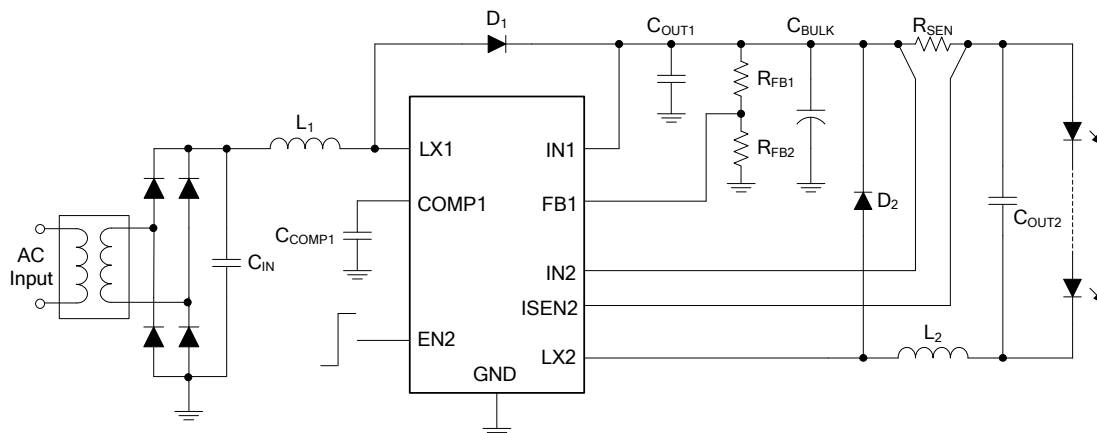
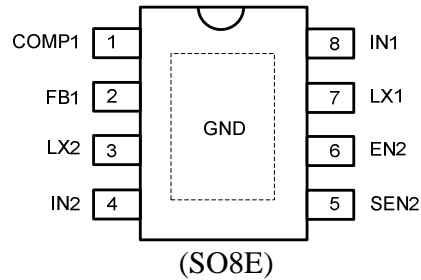

Figure 1. Schematic Diagram

Pinout (top view)



Top Mark: **AQFxyz**, (Device code: AQF, *x=year code, y=week code, z=lot number code*)

Pin Name	Pin Number	Pin Description
COMP1	1	Compensation pin for CH1. Connect a capacitor from this pin to GND
FB1	2	Feedback input and OVP input for CH1. The output voltage is within $1.0 \cdot (R_{FB1} + R_{FB2}) / R_{FB2}$ to $1.2 \cdot (R_{FB1} + R_{FB2}) / R_{FB2}$
LX2	3	Inductor node of CH2. Connect the switching node of the inductor to this pin.
IN2	4	Power supply input of CH2, also used as positive current sensing input
SEN2	5	Negative current sensing input of CH2. $I_{LED}(A) = \frac{0.1(V)}{R_{SEN}(\Omega)}$
EN2	6	Enable control. Pull high to turn on CH2. Do not float. This pin can also be used as dimming control. Apply a low frequency (<1kHz) PWM signal for PWM dimming and a high frequency (>20kHz) PWM signal for analog dimming.
LX1	7	Inductor node of CH1. Connect an inductor between power input and LX1 pin.
IN1	8	Power supply input of CH1
GND	Exposed Paddle	Ground pin

Absolute Maximum Ratings (Note 1)

IN1, IN2, LX1, LX2, EN2	-----36V
COMP1, FB1	-----3.6V
SEN2	----- $V_{IN2} \pm 0.7V$
Power Dissipation, P_D @ $T_A = 25^\circ C$, SO8E	-----3.3W
Package Thermal Resistance (Note 2)	
SO8E, θ_{JA}	-----30°C/W
SO8E, θ_{JC}	-----10°C/W
Junction Temperature Range	-----40°C to 150°C
Lead Temperature (Soldering, 10 sec.)	-----260°C
Storage Temperature Range	-----65°C to 150°C

Recommended Operating Conditions (Note 3)

IN1	-----4V to 30V
Junction Temperature Range	-----40°C to 125°C



Electrical Characteristics

($V_{IN1} = V_{IN2} = 12V$, $T_A = 25^\circ C$ unless otherwise specified)

Parameter	Symbol	Test Conditions	Min	Typ	Max	Unit
Input Voltage Range	V_{IN1}, V_{IN2}		4		30	V
CH1 Low Side Main FET RON	$R_{DS(ON)1}$			100		mΩ
CH2 Low Side Main FET RON	$R_{DS(ON)2}$			200		mΩ
CH1 Main FET Current Clamping Low Level	$I_{CLMP, LOW}$	Duty=0		1.3		A
CH1 Main FET Current Limit	I_{LIM1}	Duty=0		3		A
CH2 Main FET Current Limit	I_{LIM2}	Duty=0	2		3	A
CH1 Switching Frequency	Fsw1			400		KHz
CH2 Switching Frequency	Fsw2			300		KHz
Input UVLO Rising Threshold	$V_{IN,UVLO}$				3.9	V
Input UVLO Hysteresis	$U_{VLO,HYS}$			0.2		V
FB1 Reference Voltage	V_{REF1}		0.97	1.0	1.03	V
CH2 Current Sense Limit	$V_{IN2}-V_{SEN2}$		96	100	104	mV
CH1 OVP Rising Threshold	$V_{FB1,OVP}$			1.2		V
CH1 OVP Hysteresis	$V_{FB1,HYS}$			150		mV
Thermal Shutdown Temperature	T_{SD}			150		°C

Note 1: Stresses beyond the “Absolute Maximum Ratings” may cause permanent damage to the device. These are stress ratings only. Functional operation of the device at these or any other conditions beyond those indicated in the operational sections of the specification is not implied. Exposure to absolute maximum rating conditions for extended periods may affect device reliability.

Note 2: θ_{JA} is measured in the natural convection at $T_A = 25^\circ C$ on a low effective single layer thermal conductivity test board of JEDEC 51-3 thermal measurement standard.

Note 3: The device is not guaranteed to function outside its operating conditions

Block Diagram

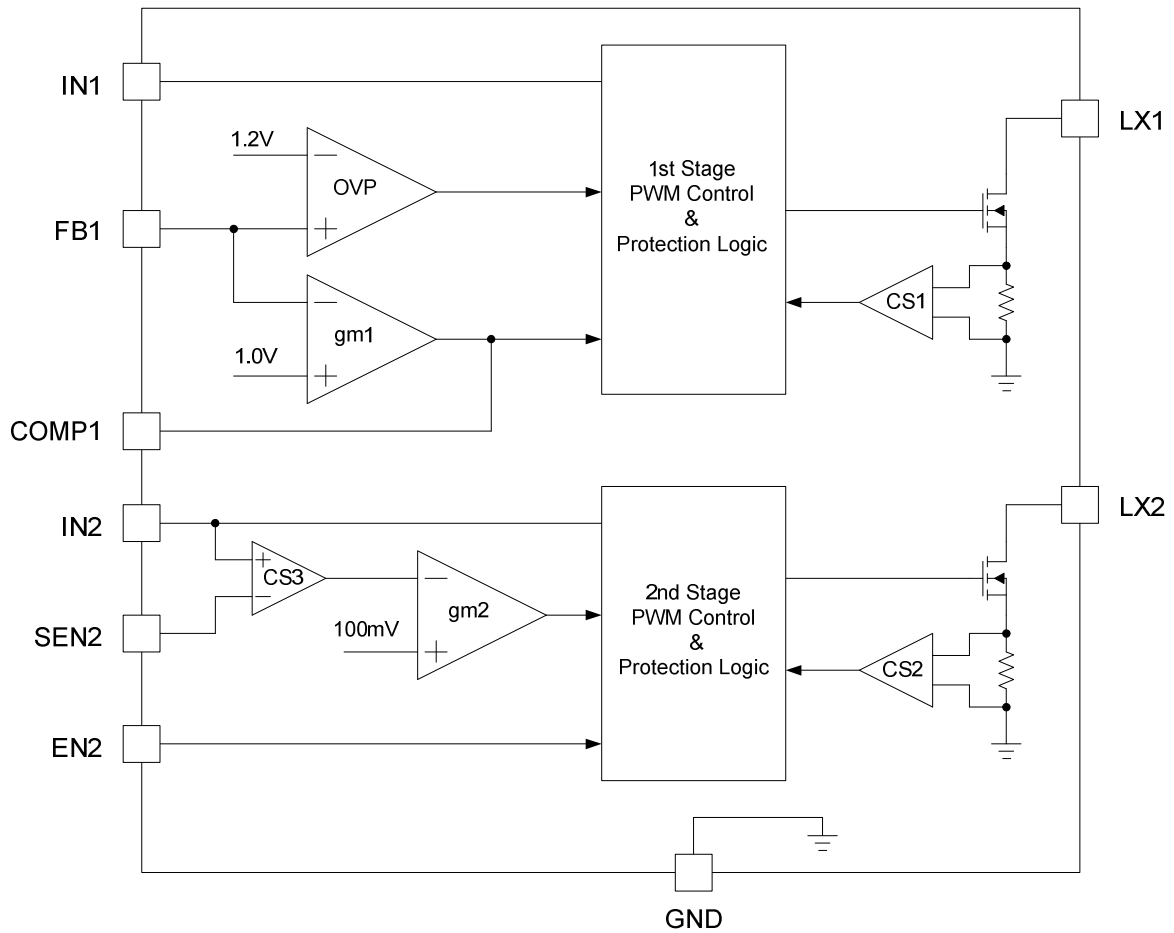



SILERGY

SY8722A

Typical Operating Characteristics

(176V~264V AC input, tested with ET-E60 electronic transformer)

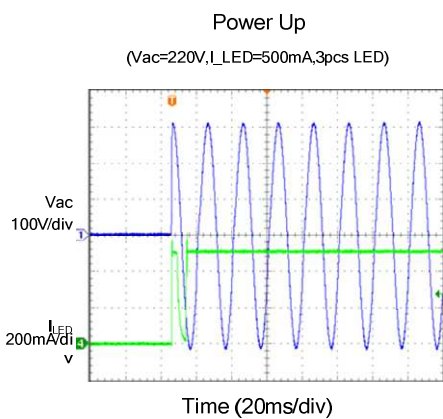
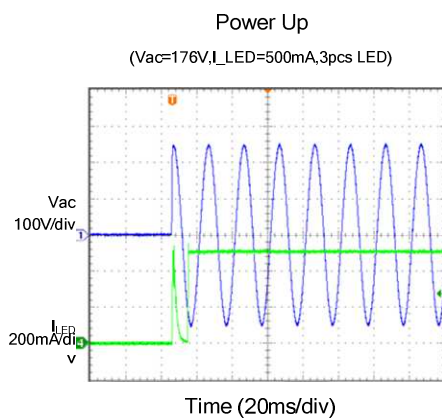
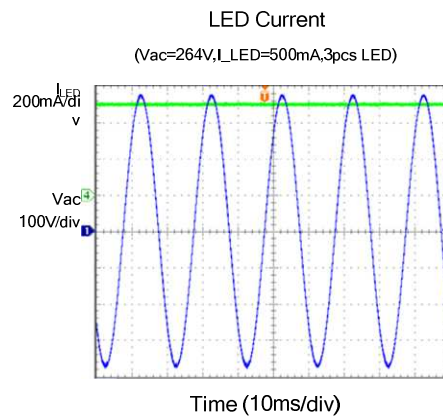
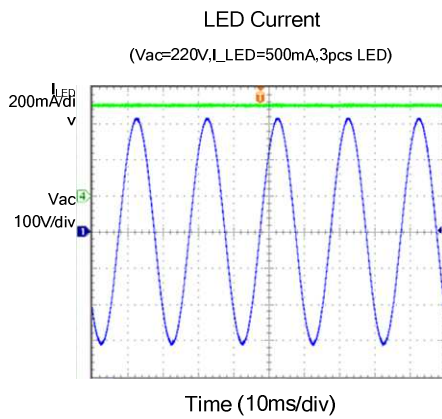
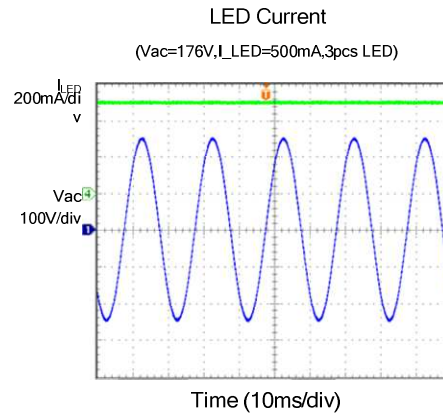
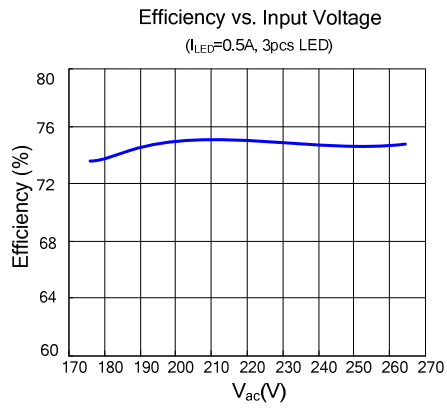



SY8722A

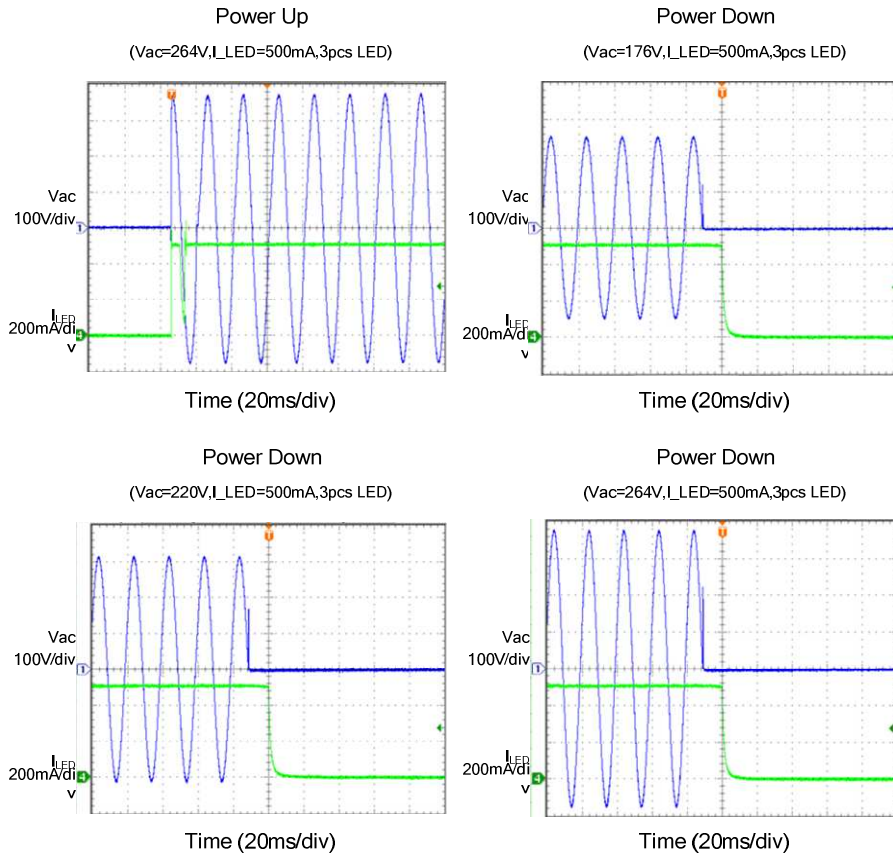



Operation

SY8722A contains a Boost voltage regulator, and a floating Buck current regulator. The voltage regulator regulates the input to a setting voltage and provides power supply for the current regulator, while the current regulator provides constant current for LED loads.

With integrated ultra low $R_{DS(ON)}$ power switches and proprietary PWM control, this regulator IC can achieve the high efficiency and the high switch frequency simultaneously to minimize the external inductor and capacitor size, and thus achieving the minimum solution footprint.

Applications Information

Because of the high integration of SY8722A IC, the application circuit based on this IC is relatively simple. Only several external components are required.

Feedback resistor divider R_{FB1} and R_{FB2} :

Choose R_{FB1} and R_{FB2} to program the minimum output voltage of the Boost regulator. To minimize the power consumption, it is desirable to choose large resistance values for both R_{FB1} and R_{FB2} . A value of between 10k Ω and 1M Ω is highly recommended for both resistors. If $R_{FB2}=13.7k$ is chosen, then R_{FB1} can be calculated to be:

$$R_{FB1} = R_{FB2} \times (V_{BUS_MIN} - 1)$$

V_{BUS_MIN} is the minimum output voltage of Boost regulator. It should be higher than the maximum input. Once R_{FB1} and R_{FB2} are chosen, the maximum output voltage of the Boost regulator is its OVP voltage that can be calculated to be:

$$V_{BUS_OVP} = 1.2 \times \left(\frac{R_{FB2}}{R_{FB1}} + 1 \right)$$

Current sense resistor R_{SEN} :

Choose R_{SEN} to program the proper output current for the Buck regulator:

$$I_{LED}(A) = \frac{0.1(V)}{R_{SEN}(\Omega)}$$

Output capacitor C_{OUT1} , C_{OUT2} and C_{BULK} :

The output capacitor C_{OUT1} and C_{OUT2} are selected to handle the output ripple noise requirements. For the best performance, it is recommended to use X7R or better grade ceramic capacitor greater than 1uF capacitance. C_{OUT1} is used to handle both output ripple of Boost regulator and input ripple of Buck regulator, the RMS current through the capacitor is relatively high. The RMS current rating of the capacitor should be considered.

The bulk capacitor is used to hold the bus voltage when the electronic transformer has no output. For most applications, it is recommended to use an aluminum electrolytic capacitor with greater than 220uF capacitance.

Compensation capacitor C_{COMP} :

In applications powered by electronic transformer, the input voltage can change roughly in one cycle of AC power frequency. A 1uF ceramic capacitor connected from COMP1 pin to ground help to stabilize the control loop of the Boost regulator.

Output inductor L_1 and L_2 :

It is very critical to select the Boost inductor for better efficiency and higher PF. With propriety control scheme, the Boost regulator is quite tolerant with difference inductance. So we can select the Boost inductor according to Buck output power.

For the Buck regulator, it is suggested to choose the ripple current to be about 40% of the maximum average inductor current. The inductance is calculated as:

$$L_2 = \frac{V_{LED}(1 - V_{LED}/V_{BUS_OVP})}{F_{SW2} \times I_{LED} \times 40\%}$$

Where F_{sw2} is the switching frequency of Buck regulator and I_{LED} is the LED current.

The saturation current rating of L_2 must be selected to be greater than the peak inductor current under full load conditions.

$$I_{SAT} > I_{LED} + \frac{V_{LED}(1 - V_{LED}/V_{BUS_OVP})}{2 \cdot F_{SW2} \cdot L_2}$$

SO8E Package outline & PCB layout design

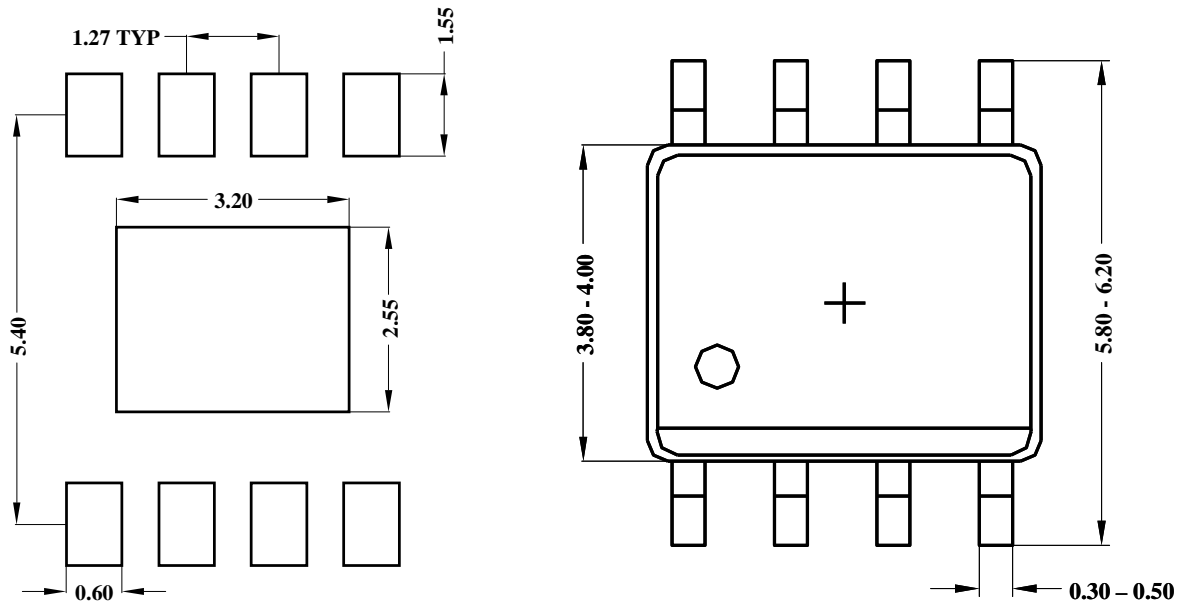

Recommended Pad Layout

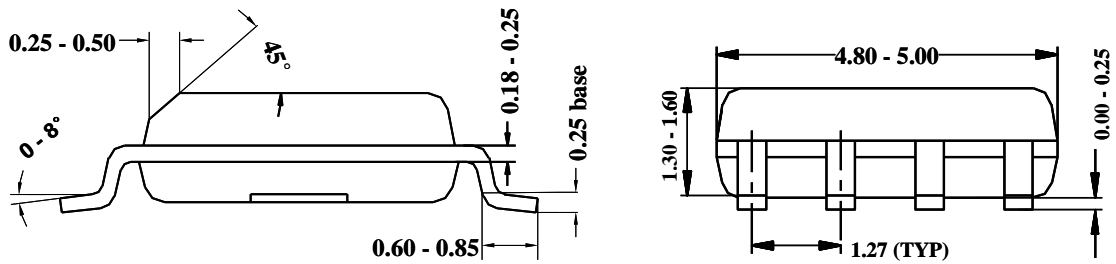

**Notes: All dimensions are in millimeters.
All dimensions don't include mold flash & metal burr.**